



# VOLTAGE CONTROLLED TRANSIENT GENERATOR

## DESCRIPTION

The SSM 2056 is a precision, self-contained, four section voltage controlled transient generator designed for easy use in programmable electronic music systems. The device offers near zero offset and control feedthrough, standard 5V peak output and an exponentially controlled 50,000 to 1 range on all timing inputs. Sustain voltage level can be varied from 0 to 100%. In addition, all control inputs are gangable and referenced from GND up allowing easy interface with electronic controllers and programmers.

## FEATURES

- Full ADSR Response
- Low Cost
- Independent Gate and Trigger
- Minimum external component count
- True RC contour
- $\pm 15$  V supplies
- Small fixed final decay and sustain voltage offset
- Output short circuit protected
- Negligible control feedthrough
- 5 V peak output
- Gangable control inputs
- Minimum 50,000 to 1 exponential time control range
- All input controls positive going from GND
- Output can drive heavy RC loads without degrading performance

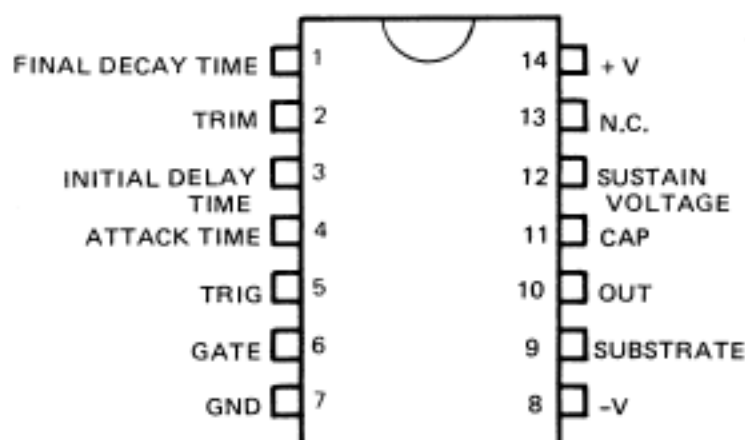

PIN DIAGRAM - TOP VIEW

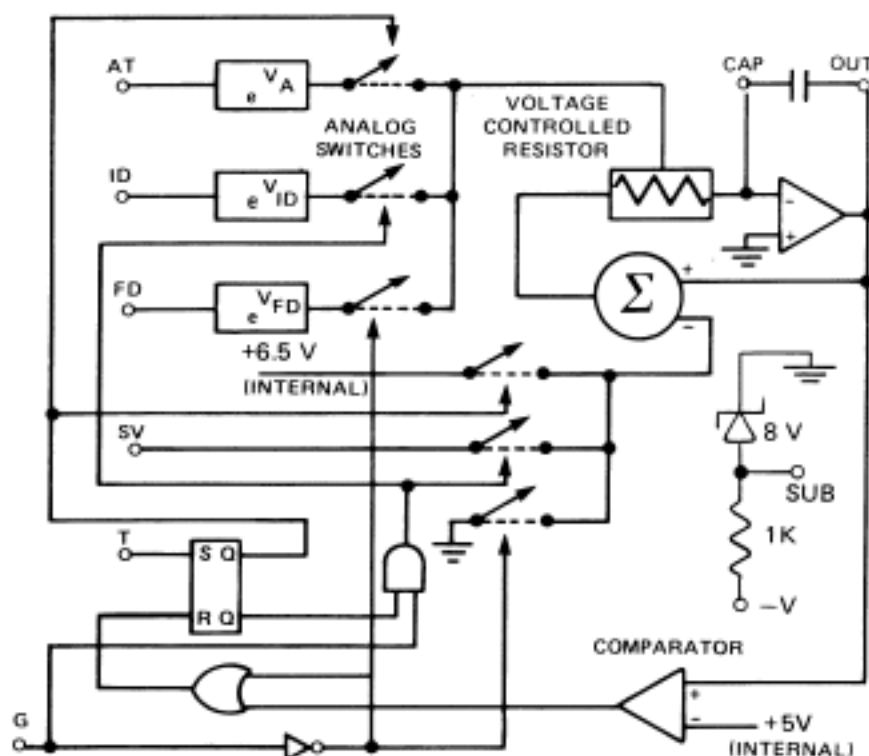

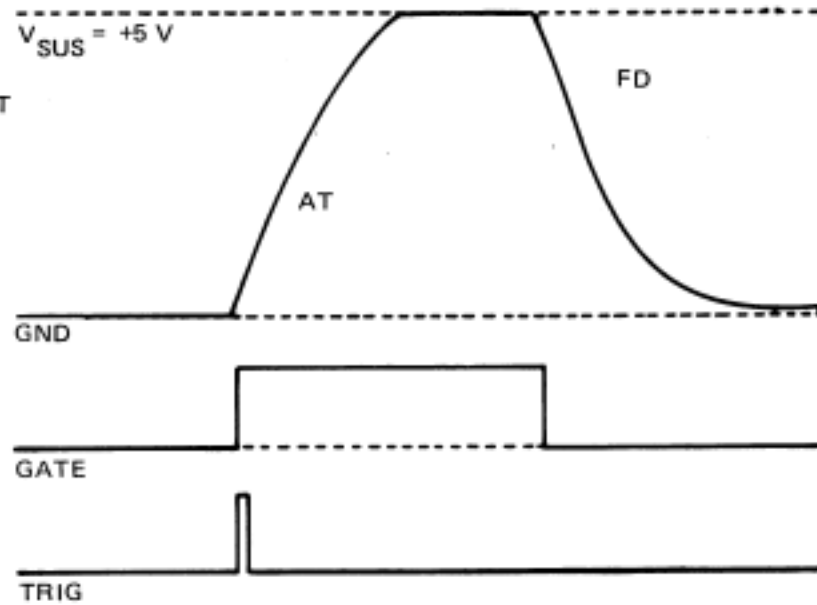
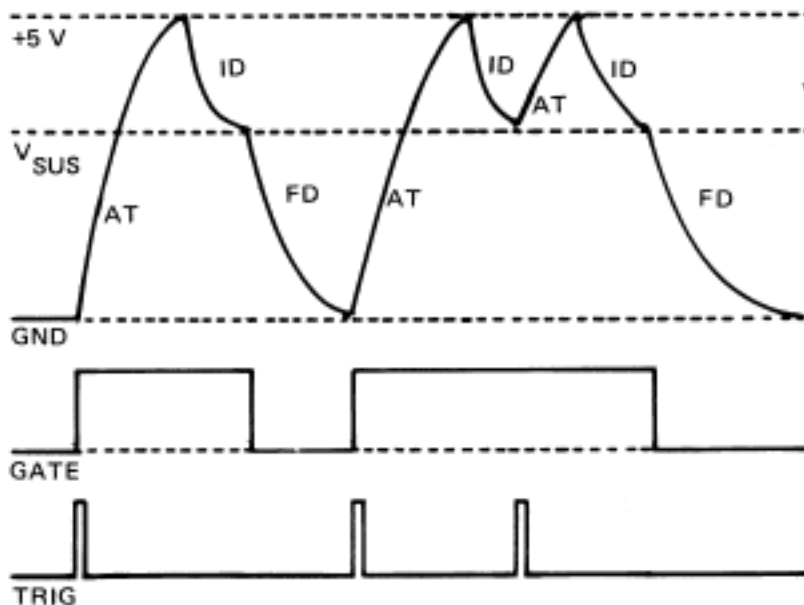

## DIAGRAM DESCRIPTION

AT, ID, FD indicate times controlled by Attack, Initial Decay and Final Decay Time Control inputs respectively. (A positive going voltage increases the time constant.) All phases of the waveform are true exponential approaches to +6.5 V, Sustain Voltage and Ground respectively.

## ELECTRICAL SPECIFICATIONS\* @ $V_S = \pm 15$ and $T_A = 25^\circ\text{C}$

PARAMETER	MIN	TYP	MAX	UNITS	CONDITIONS
Positive Supply Current	4.00	5.8	9.00	mA	Pin 8, $V_{ee} = -15\text{ V}$
Negative Supply Current	6.0	8.65	12.0	mA	
Positive Supply Range	+5	+15	+18	V	
Negative Supply Range <sup>(1)</sup>	-4	-	-18	V	
Gate Threshold Voltage	1.0	1.15	1.3	V	$V_G > 1\text{ V}$ $V_G = \text{GND}$  $V_T > 0.8\text{ V}$
Gate Current (High)	-1	0	+1	$\mu\text{A}$	
Gate Current (Low)	-	-14	-40	$\mu\text{A}$	
Trigger Threshold Voltage	1.0	1.65	2.0	V	
Trigger Input Impedance	5.14	6.85	8.56	$\text{K}\Omega$	
Trigger Threshold Current	50	130	175	$\mu\text{A}$	
Time Control Range	50,000:1	250,000:1	-	mV/Decade ppm/ $^\circ\text{C}$	
Time Control Sensitivity	-	+ 60	-		
T.C. of Time Control Sensitivity	-	+ 3300	-		
Unit to Unit Time Constant Variation (untrimmed)	0.75	1	1.30		
Attack Voltage Asymtote	6.3	6.5	6.7	V	$0 < V_{AT} < 240\text{ mV}$ $0 < V_{ID} < 240\text{ mV}$ $0 < V_{FD} < 240\text{ mV}$
Peak Attack Voltage	4.9	5.0	5.1	V	
Attack C. V Feedthrough	-	0.5	2.5	mV	
I.D. C. V Feedthrough	-	0.5	2.5	mV	
F.D. C. V Feedthrough	-	3	13	mV	
Sustain Voltage Offset $V_o - V_{SV}$	-10	-18	-23	mV	At Final Value
Final Decay Offset $V_o$	-10	-18	-23	mV	At Final Value
Integrator Input Current	-	0.1	1	n A	
Sustain Voltage Input Current	-	0.5	1.4	$\mu\text{A}$	
Available Output Sink Current	1.2	1.6	2.0	mA	
Positive Output Short Circuit Current	4.0	6.5	10.0	mA	

## NOTES

\*Final specifications may be subject to change.

<sup>(1)</sup> Pin 9 is used for negative supply voltages  $-4\text{ V} > V_{ee} \geq -7\text{ V}$ .

Pin 8 is used for negative supply voltages  $-8\text{ V} > V_{ee} \geq -18\text{ V}$ .

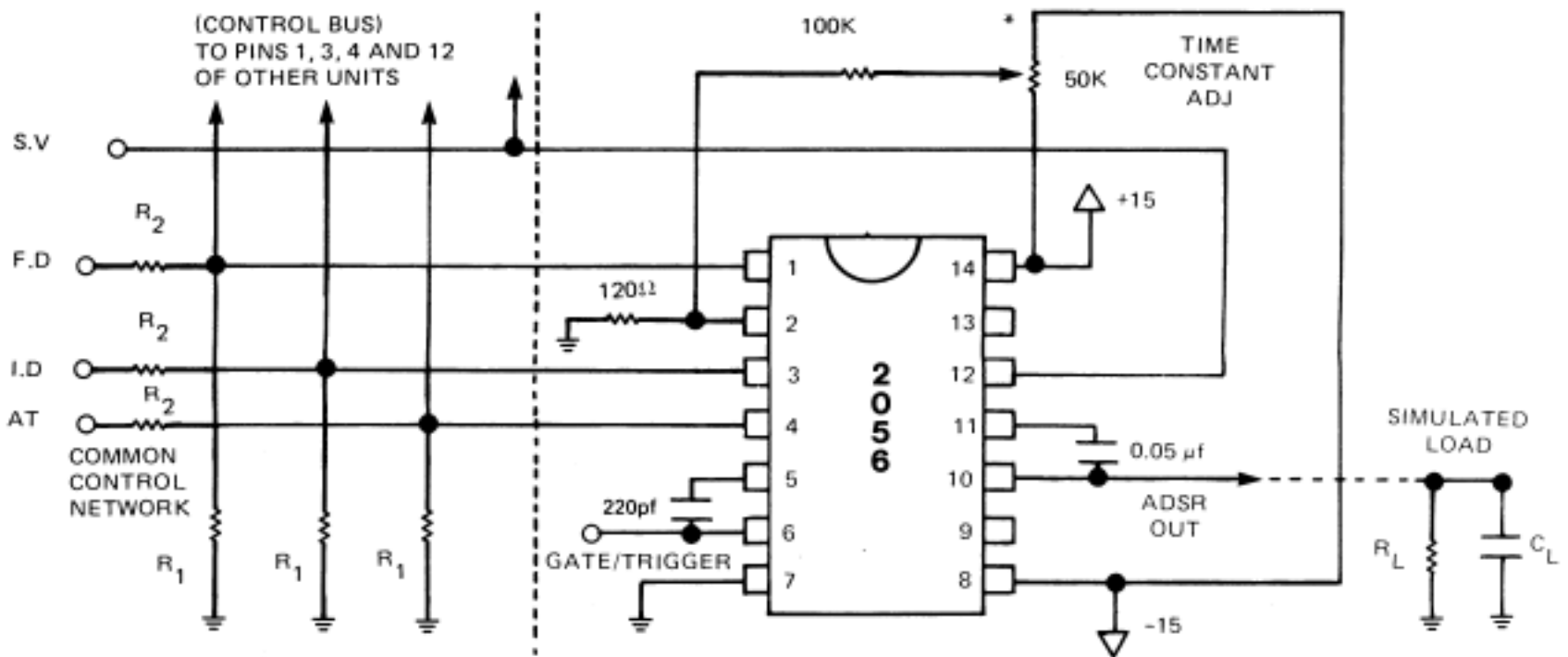

\*Optional: Adjusts for capacitor value and slight unit to unit variation. Ground Pin 2 if not required.

### TYPICAL CONNECTION

The diagram above shows the typical connection for a polyphonic system. The control attenuators on the left are common to all 2056's used for the same function within a voice; such as control of the final VCA. The sense of the control is from Ground up with minimum time periods at GND and increasing times at positive voltages. Some recommended resistor values for often-used sensitivities are given along with the general design equations below. The temperature coefficient of the time sensitivities can be compensated by using Tel Labs Q81C or TRW RGT series thermistors for the  $R_1$ 's.

The time constant adjustment is necessary in polyphonic systems to make all voices sound the same for long attack times. The procedure is to set the AT control for the longest required attack time, ground I.D., F.D. and S.V., and adjust each 2056 to give exactly the same attack period; 10 to 20 seconds is about the longest that is musically useful. The adjustment can be ignored in manually controlled monophonic systems.

The Gate/Trigger input(s) can be driven directly from the outputs of all TTL and CMOS logic families. The ADSR output can drive any grounded load  $R_L > 2.5K$ ,  $C_L < 1000pf$ .

Natural acoustic instruments that have tone sources that are plucked or struck have envelopes that vary with the pitch produced (high notes have faster decay times than low notes). This effect can be duplicated using the 2056 by routing the keyboard voltage to the trim input.

The trim input (PIN 2) has an exponential response and is connected to all the timing control cells. Although it has the same scale factor as the timing inputs, it has the opposite polarity (increasing voltage decreases the time constants).

### Design Equations

$$t_A = 0.5m \text{ sec} \uparrow \left\{ e^{\left\{ + \frac{V_{AT} R_1 q}{(R_1 + R_2) kT} \right\}} + 1 \right\}$$

$$t_{ID} = 0.5m \text{ sec} \uparrow \left\{ e^{\left\{ + \frac{V_{ID} R_1 q}{(R_1 + R_2) kT} \right\}} + 1 \right\}$$

$$t_{F.D.} = 0.5m \text{ sec} \uparrow \left\{ e^{\left\{ + \frac{V_{FD} R_1 q}{(R_1 + R_2) kT} \right\}} + 1 \right\}$$

$$\frac{kT}{q} = 26mV @ 25^\circ C$$

### NOTES

† Nominal Time Period with  $V_{AT} = V_{ID} = V_{FD} = 0V$  and  $C_T = 0.05\mu f$  is 1m sec.

†† Tel Labs Type Q81C =  $60 \Omega @ 25^\circ C$   $R_1$  should be kept as small as possible when the control attenuator is driving many units.

### Design Table

Input Sensitivity	$R_1$	$R_2$
1V/Decade	$60\Omega \uparrow \uparrow$	$940 \Omega$
1V/Octave	$60\Omega \uparrow \uparrow$	$3.3k\Omega$
1V/Decade	$100\Omega$	$1.5k\Omega$
1V/Octave	$100\Omega$	$5.4k\Omega$
1V/Decade	$250\Omega$	$3.9k\Omega$
1V/Octave	$250\Omega$	$13.6k\Omega$